



Working with Interactive Documents

Special for EA Global Summit 2020

In this presentation, Ian will describe how to generate interactive Word documents from your EA models, and use them to automate your model updates.



My biases – the ones I know about

- EA user since v3.5
- Business analyst, process modeller, team leader, consultant
 - So I don't know SysML or Archimate
- Rather spend 4 hours writing a script than 20 minutes doing something dull
 - BIG bias towards tools
- EA drives me CRAZY
 - But I never use anything else
- Used EA in teams of 2-20
- Worked with EA teams of 2-200



Problem statement



EA can contain all the business knowledge we need to create great documents

The trick is getting people to:

Read

Understand

Interact..

..with those documents

Assumptions:

- Document readers almost certainly won't use EA
- They might not even want to use Prolaborate 😞
- They probably already use Word and MS Teams / Sharepoint
- And they know how to do reviews..
- ...so use the same tools that they do

Agenda



What tricks can we use to make people

Read

Understand

Interact..

*World premier of some super
new function here*



..with those documents

Deep-dive into a typical document



This example created using:



Other tools are available: not sure which ones allow which of these features

Many points are tool-independent

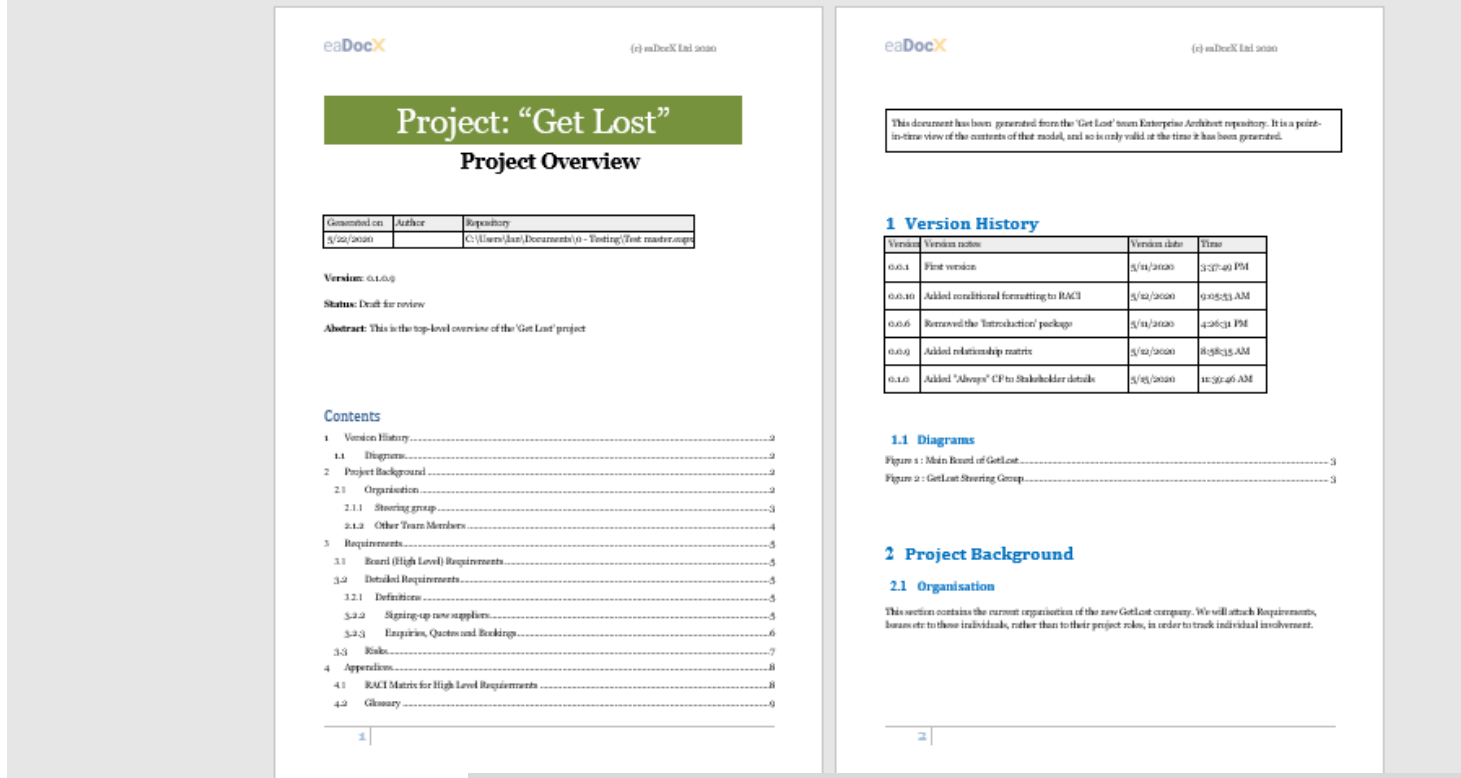
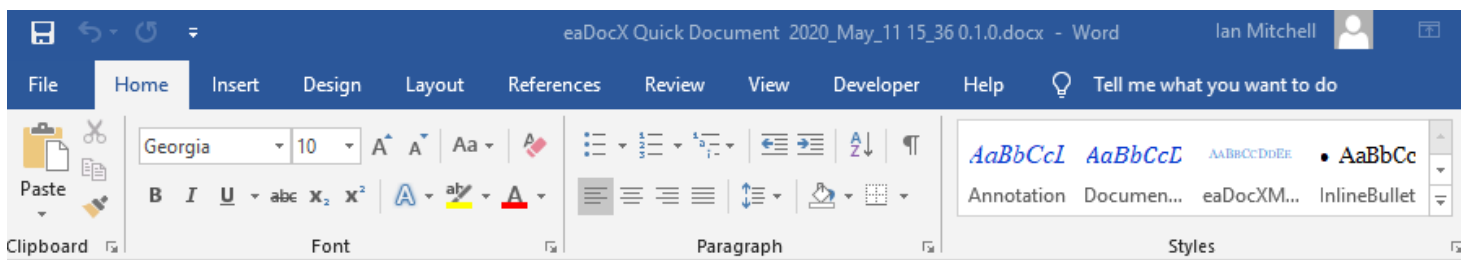

- No surprises – make it look like a regular Word document
- Usual ToC, ToF , Header page
- Reader should not know difference between generated and non-generated content



Contents

1	Version History	1
2	Project Background.....	2
2.1	Organisation	2
2.1.1	Steering group.....	3
2.1.2	Other Team Members.....	4
3	Requirements.....	4
3.1	Board (High Level) Requirements	4
3.2	Detailed Requirements	5
3.2.1	Definitions	5
3.2.2	Signing-up new suppliers	5
3.2.3	Enquiries, Quotes and Bookings	5
3.3	Risks.....	6
4	Appendices	7
4.1	RACI Matrix for High Level Requierments.....	7
4.2	Glossary.....	7

- Keep main part of document SMALL
- Put 'other stuff' into appendices
- Use hyperlinks to link 'main' and 'other'

Great documents from great models

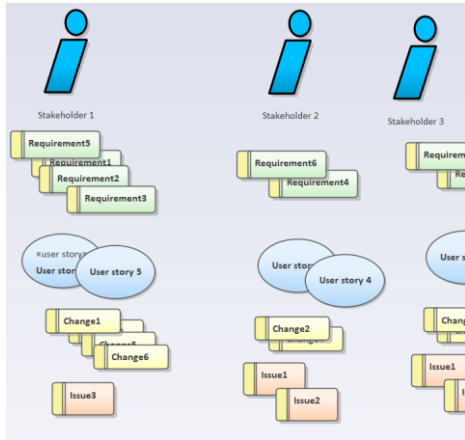

'Everything'
document

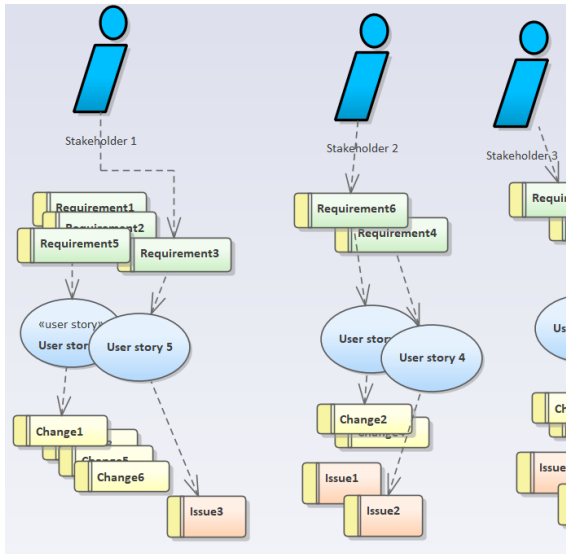
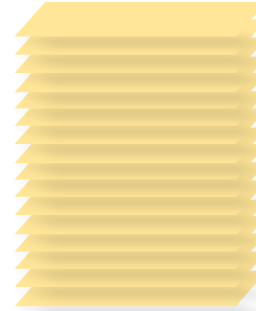

Stakeholder 1
document



Stakeholder 2
document



Stakeholder 3
document

Great documents from great models

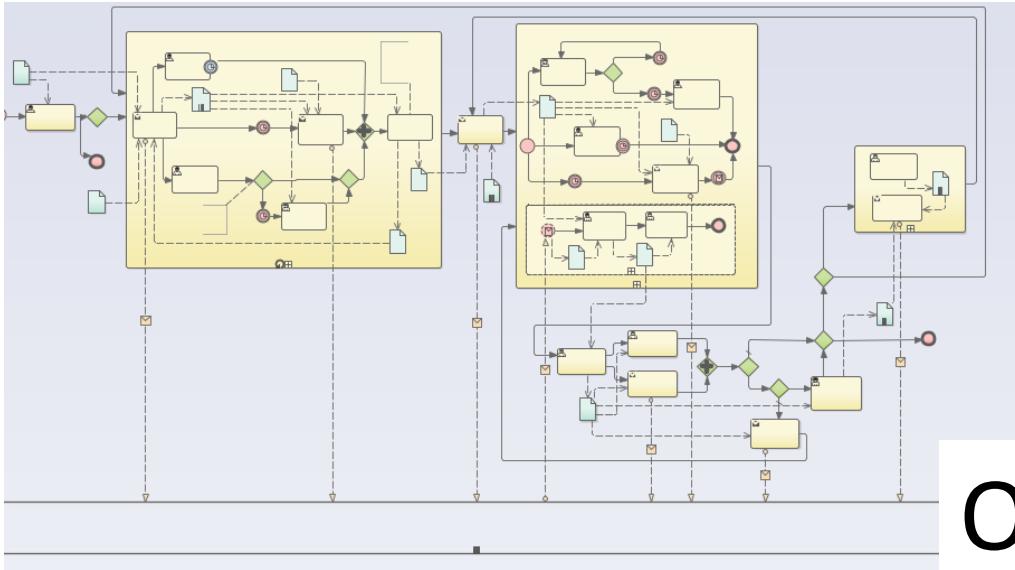

Look how clever I am...

OR

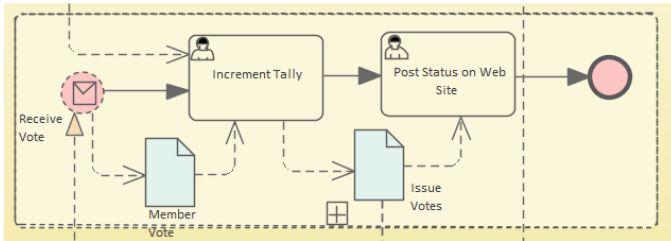

"This diagram shows the..."

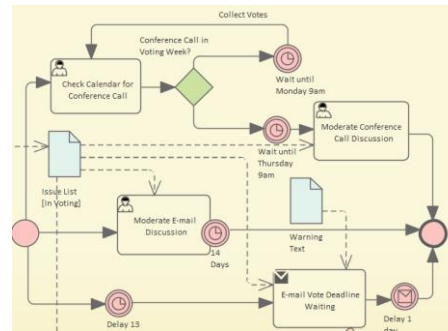

"This diagram shows the..."



2.1.2 Other Team Members

Team member	Details	Reports to
Jenn Thorson - CLO	Chief Legal Officer	Martin Jones - CEO
Pierre Carandini - CFO	Chief Financial Officer	Martin Jones - CEO
Barbara Allen-Jones - Test Manager	Responsible for the acceptance testing of the solution which is provided by the supplier of the GetLost software, and for running the User Acceptance Test.	Nick Adams - Project Manager (Launch)
Mand Sharma - Business	Responsible for production of: <ul style="list-style-type: none"> Initial requirements set 	Nick Adams - Project

Color is not just for fun:

'People' tables are blue

3.1.2 Signing-up new suppliers

Requirement	Details	owned by	Ref
Sign-up	There will need to be a process for signing-up new suppliers. Suppliers systems should all conform with the TBML (Travel Booking & quotes Markup Language) standard, otherwise we will have to produce bespoke interface code for each supplier.	Mark Ellsworth - CMO	REQ000
Role of TBML	All TBML-compliant suppliers get paid via the TBMLCo. Payment Settlement System (PSS), where consumer companies (like GetLost) pay Suppliers once a month, via a single payment to	Clare Smart - COO	REQ001

'Requirements' tables are green



I make 'EA Connectors',
You see hyperlinks



	HL_REQ_1	HL_REQ_2	HL_REQ_5	HL_REQ_3	HL_REQ_4
	Providers	Options	KPIs	Payments	Quotes
Martin Jones - CEO	I	I			I
Clare Smart - COO			C		
Frank Bey - CTO					
Mark Ellsworth - CMO	A				A
Jilly Smart - Product Manager	R	R			R
Beth Robinson - Operations Manager				R	
Marc Leclerc - Programme Manager					

(created using eaDocX Relationship Matrix, with hyperlinks for the people, additional header rows and conditional formatting)

4.2 Glossary



These are the terms from the central Enterprise Architect repository which appear in this document. The table will change as the content of the above document changes

Term	Definition
TBML	Travel Business Markup Language. A set of standards for the exchange of travel industry knowledge.
RACI	Responsible, Accountable, Consulted, Involved. This is a way to show the relationships between a requirement and the stakeholders who are involved with it.

Glossary is important:
explains the terms.
..but keep it 'right-sized'



*“Maybe the document is now a bit interesting.
Maybe I’ll read it
Maybe I’ll interact with it...”*

Interactive Documents

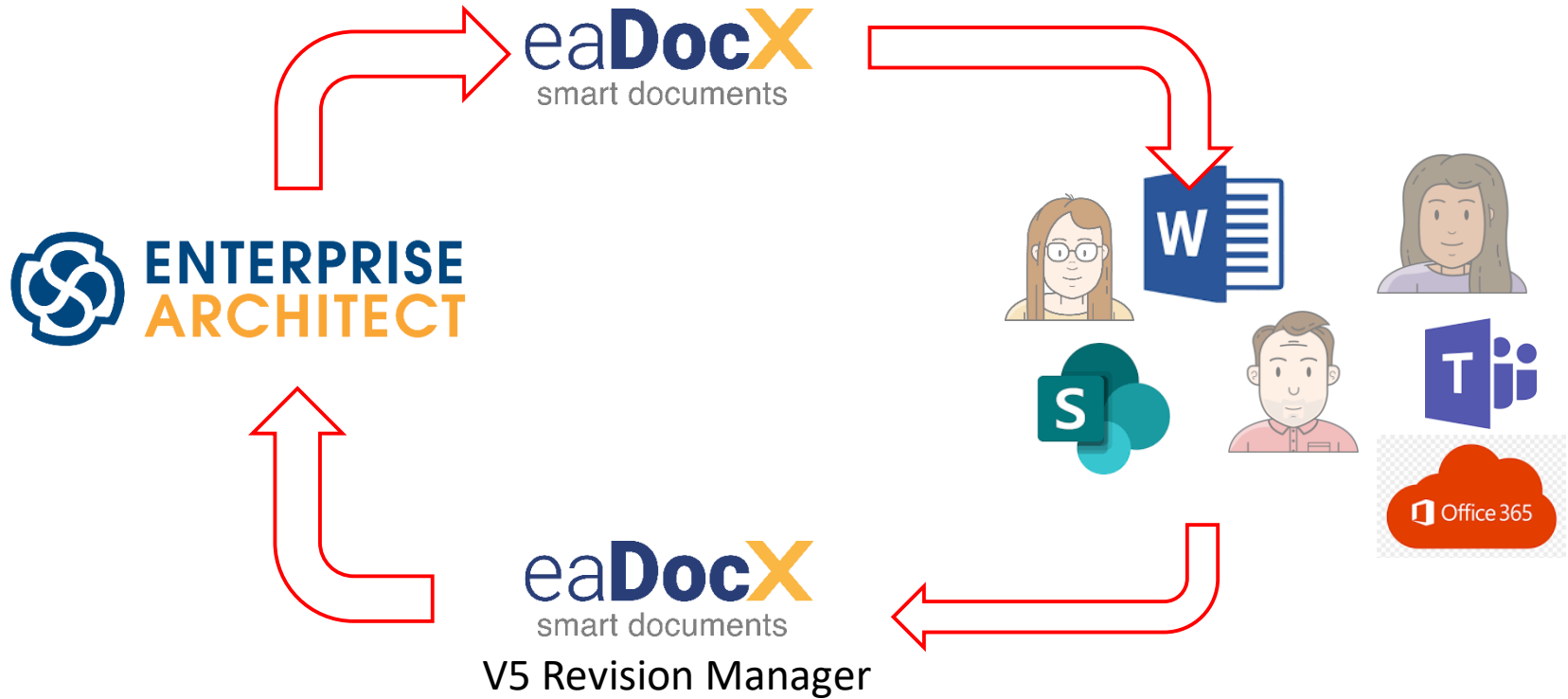

Introducing....



The next generation of

Interactive EA Documents

Note: this is a DRAFT document, where we require your input.

Sections like this

show where we **NEED** your input.

You can also overwrite any part of the document, or make comments.

.
. .
.

2.1 Actors

Actor	Details	See use cases
TBMLCo.		-
Manager		Establish non-TBML supplier
Browser	An anonymous person, just browsing around the net.	Search for Travel

Reviewers do what they want..

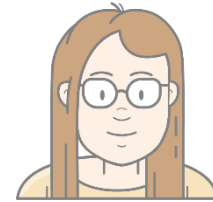
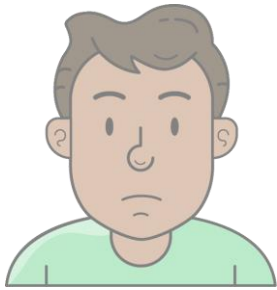

Reviewers do what they want..

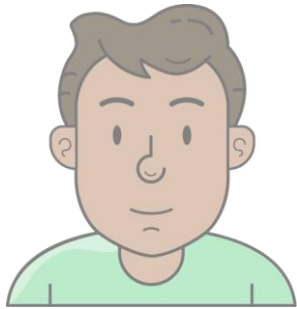

Charlie
Can't we make this simpler?



2.1 Actors

Actor	Details	See use cases
TBMLCo.		
Manager	<u>A Manager is a kind of super-user, who can perform some admin tasks which are not available to other users. That's because those tasks have a big effect on how the system works</u>	<u>Establish non-TBM supplier</u>

Comments and revisions from one person



Details: ??? Surely we don't need to invest this process yet again? Can't we just lift some industry best practice from somewhere?

I Agree – why can't we partner with Google or Facebook, and use their registration data? Much simpler for the users



Comments and revisions from multiple people

The worst job...

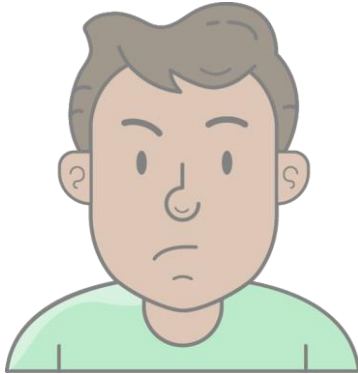

2.1 Actors

Actor	Details	See use cases
TBMLCo.		-
	A Manager is a kind of super-user, who can perform some admin tasks which are not	Establish

Details: ??? Surely we don't need to invest this process yet again? Can't we just lift some industry best practice from somewhere?

I Agree – why can't we partner with Google or Facebook, and use their registration data? Much simpler for the users

Lots of updates from
Lots of people in
Lots of documents

ing Issues: -

UC05 : Register

The use case starts when a user reaches a point in the system where the system need to register. asks them for:

nal), first name, last name, email address (twice) and password(twice)

validates that the password meets our standards

sends them an email, and their registration is in a 'pending' state until a response is received



See requirement: -

Actor(s): -

2.2.1.2.1 Scenarios

(none)

Do the easy stuff fast



eaDocX Revision Manager* smart documents

Source word document: Analysis Summary v0.1.7.4

Revision Document	Authors	Feedback
Analysis Summary - feedback from Charlie.docx	Charlie	Comments: 1, Revisio...
Analysis Summary - IEM Comments.docx	Ian M, Clare F	Comments: 1, Revisio...

Revisions:

Charlie	The use case starts when a user reaches a point in the system wh...	...	✓
Ian M	Surely we don't need to invest this process yet again? Can't we j...	...	✓
Clare F	Details: ??? Surely we don't need to invest this process yet again...	...	✓

Pending changes

Element	Field / Tagged value	New value	oldValue
---------	----------------------	-----------	----------

Buttons: Save with details, Save to Model, Close

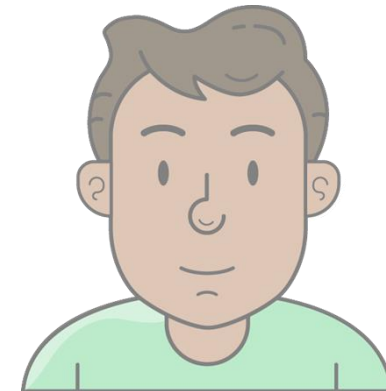

* Part of eaDocX Collaboration Edition, to be delivered in eaDocX V5

Reviewing interactive documents



- Allow reviewers to use technology they already have, and already know:
 - Each user has their own copy, makes one set of comments
 - Multiple users review a single copy, for example, in MS Teams
 - Reviewers collaborate THEIR way
- No new infrastructure, no need to teach new skills



Processing interactive documents



- Pull all versions of the same document into eaDocX Revision Manager
- See where multiple users have commented/revised the same EA element/field
- Pull data quickly back into EA
- Optionally, create audit trail in EA

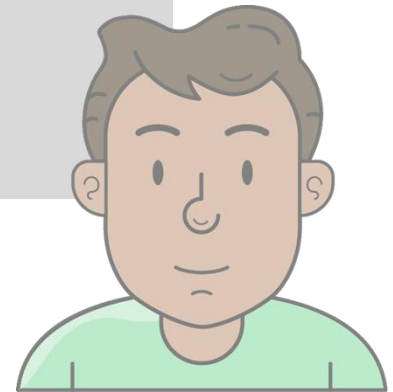

Smart documents

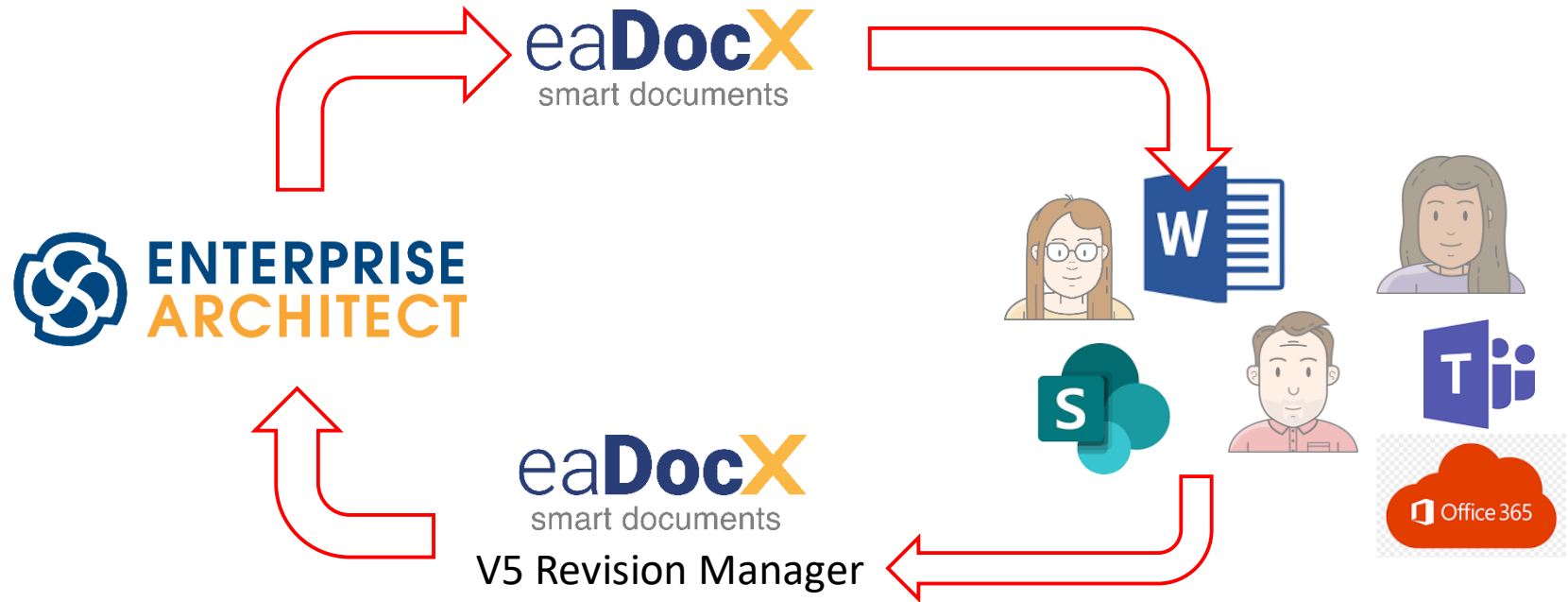

- eaDocX V4 available now at www.eaDocX.com
- 30-day free trial
- eaDocX V5, with Revision Manager and Interactive documents, coming later in 2020

About eaDocX



- **Most successful EA addin:**
 - >3000 customers
 - 10 years of document generation
 - Current version :
 - V4 – production
 - V5 Beta – with new Revision Manager

Edition	Professional	Corporate	Collaboration
Function	High quality documents, template, quick documents	+ Excel round-trip + document management + HTML generator	+Interactive documents + Revision Manager
Single user	USD217	USD395	USD395*
Group licence / user / year	USD <100	USD < 200	USD < 200*

* Until end 2020